

**SMART MAX GEOSYSTEMS CO., LTD**

www.smartmaxgeosystems.com info@smartmaxgeosystems.com

ADD: FLAT 601, 6/F, VASTKIN HOUSE, 84 JERVOIS STREET, SHENG WAN, HONG KONG, CHINA.

---



**SMART MAX GEOSYSTEMS**

**CST3M Desktop Mapping Equipment**

**Calibration Table**



# SMART MAX GEOSYSTEMS CO., LTD

www.smartmaxgeosystems.com info@smartmaxgeosystems.com

ADD: FLAT 601, 6/F, VASTKIN HOUSE, 84 JERVOIS STREET, SHENG WAN, HONG KONG, CHINA.

---

## 一、CST3M 型桌面式测绘仪器检校台

### CST3M Desktop Mapping Instrument Calibration

主要技术特点

#### The main technical characteristics

- 1、本机彩用焦距为 420 的平行光管，设计制作成水平角、俯角、仰角、共三支平行光管。

The machine adopts the focal length is 420 of parallel light pipe, design and production into a horizontal Angle, dip Angle and elevation Angle, a total of three parallel light pipe.

- 2、平行光管安装有精度为 20” 的高精度十字分划板，搭配检测高精度测量仪器，具有很高的检测精度。

Parallel light pipe installation of high accuracy of the 20” the reticle, tie-in detection precision measuring instruments, has the very high accuracy.

- 3、平行光管前后都留有一定标准的调整范围，具有较高和灵活的检测调试方法。

Parallel light pipe bore a certain standard before and after the adjustment range, with high and flexible testing debugging method.

- 4、平行光管使用最新的高寿命“冷”光源，光源强度可由用户自由调整。

Parallel light pipe using the latest high life "cold" light source, the intensity of light source can be adjusted by the user.

- 5、升降工作台的上下升降范围达 30cm 的螺杆，(上中下中心留有通光口径可检测经纬仪光学对点系统)，使用户更加得心应手及仪器搭配更加广泛。

Lifting worktable's lifting up and down range up to 30 cm of the screw, (there is optical aperture to detect the optical theodolite on the point system), it makes the user more handy and equipment collocation more widely.

# SMART MAX GEOSYSTEMS CO., LTD

www.smartmaxgeosystems.com info@smartmaxgeosystems.com

ADD: FLAT 601, 6/F, VASTKIN HOUSE, 84 JERVOIS STREET, SHENG WAN, HONG KONG, CHINA.

6、升降工作台安装有大型旋转手柄，操作灵活。

Lifting work also is equipped with large rotating handle, with flexible operation.

7、升降台配有公、英两用仪器中心螺丝，可搭配检测不同的进口、国产测量仪器。

Lifting platform is equipped with instrument center screw, can match different detection of imports, domestic measuring instrument.

8、底座设计有四个调平螺栓，下方配合四个圆型垫块，增大了受力面积，稳定性非常强。

Below the base design with four leveling bolts, and four circular pad, increases the stress area,so the stability is very strong.

9、底座为设计制作的大型基座，设备总重量近 100kg 增强了稳定性。

There is a large design and production base, and the equipment total weight 100 kg, enhancing the stability.

10、产品具有造型美观大方、设计紧凑、占地面积小，方便安装，稳定性强等特点。

Products with beautiful modelling, compact design, cover small area, convenient installation, strong stability, etc.

## 二、CST3M 型桌面式测绘仪器检校台 主要技术参数

○平行光管数量 3 支（竖轴仰角、水平角、俯角、三支平行光管）

Three parallel light pipe (Three parallel light pipe:

Vertical shaft angle, Horizontal angle, Angle of depression)

○平行光管镜筒长：420mm

The length of parallel light pipe barrel : 420mm

○有效孔径：55mm

Effective aperture: 55mm

# SMART MAX GEOSYSTEMS CO., LTD

www.smartmaxgeosystems.com info@smartmaxgeosystems.com

ADD: FLAT 601, 6/F, VASTKIN HOUSE, 84 JERVOIS STREET, SHENG WAN, HONG KONG, CHINA.

---

○焦距：420mm

Focal length: 420mm

○精度（分划板格值）：20”

Precision( Reticle lattice value): 20”

○升降台最大工作范围：30cm（包含通光口径）

Elevating stage of the maximum working range(including optical path aperture): 30cm

○放大倍率：5.7~7 倍

Magnification ratio: 5.7~7 times

○视场角：10° 20′

Angle of view: 10° 20′

○分辨率：3”

Resolution: 3”

○检校台尺寸：105 高×115 长×40cm 宽。

Calibration table size:105high×115length×40wide(cm)

○总重量：60kg 目测视距：15~30cm

Total weight: 240kg Visual range: 15~30cm

○水准器灵敏度 Level sensitivity

○基座圆水准器： $\Delta \leq 8'' / 2\text{mm}$

Base circular bubble leveling instrument:  $\Delta \leq 8'' / 2\text{mm}$

○准直微动器长水准器： $\Delta \leq 10'$

Collimating micro actuator long leveling instrument:  $\Delta \leq 10'$

○电源电压：3.4~4.2V 2.1W

Power supply voltage: 3.4~4.2V 2.1W

○开关电源：I=10A

Switching power supply: I=10A

○光源照明：冷光源（强弱度可微调）绿色、白色

# SMART MAX GEOSYSTEMS CO., LTD

www.smartmaxgeosystems.com info@smartmaxgeosystems.com

ADD: FLAT 601, 6/F, VASTKIN HOUSE, 84 JERVOIS STREET, SHENG WAN, HONG KONG, CHINA.

Lighting: Cold light source(The intensity of trimming)

## 注意事项

### Matters needing attention

- 接通电源时选择符合本机的工作电压（220V±10%）

When the power supply is switched on, select the machine working voltage(220V±10%)

- 平行光管照明线及开关插头电源线要避免被挤压扭曲、切忌拉扯光管照明电源线。

Parallel light pipe line and switch plug power line need to be avoided being distorted, do not pull the light pipe illumination power line.

- 已调整安装好的测绘仪器检校台建议摆放在通风且采光好的专业工作室

The surveying and mapping instruments calibration station which has been mounted for adjustment well should be placed in the ventilation and daylighting good professional studio.

- 不要随意触动已调试好的平行光管及其精密装置。

Don't touch the debugging parallel light pipe and its precision device

- 请注意保养各电镀及发黑部件，使用清洁柔棉布细微擦拭。

Please pay attention to maintenance of the plating and black member, and use clean soft cloth to wipe the subtle.

※警告：请勿自行拆卸电源及平行光管等精密物件。

※Warning: Do not disassemble the power source and the parallel light pipe and other precision object.

在不使用时，请关上电源开关及拔下电源插头。

When not in use, please turn off the power switch and pull out the power plug.

# SMART MAX GEOSYSTEMS CO., LTD

www.smartmaxgeosystems.com info@smartmaxgeosystems.com

ADD: FLAT 601, 6/F, VASTKIN HOUSE, 84 JERVOIS STREET, SHENG WAN, HONG KONG, CHINA.

## CST3M 型测绘仪器检校台结构示意图

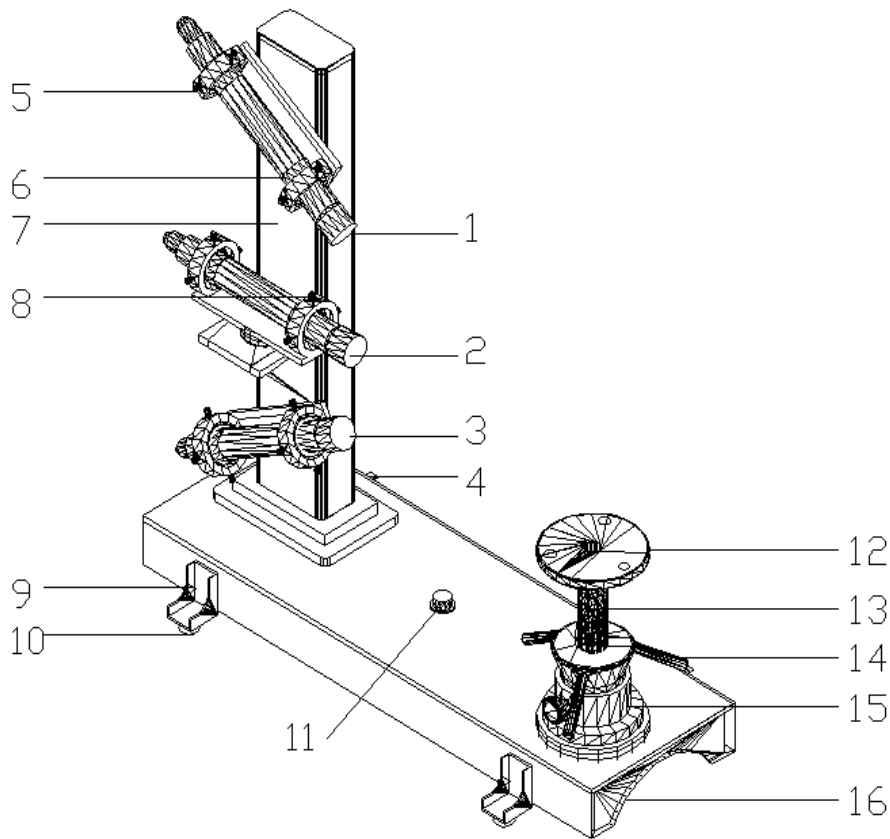

- 1、平行光管（俯角）
- 2、平行光管（准直水平角）
- 3、平行光管（仰角）
- 4、立柱、底座连接螺丝
- 5、调整紧固环座
- 6、固定调整环座
- 7、立柱
- 8、平行光管调整锁紧螺丝

- 9、底座调平螺栓
- 10、底座安平垫块
- 11、调平圆水准器
- 12、仪器工作台
- 13、升降螺纹丝杆
- 14、升降手柄
- 15、升降制动螺栓
- 16、底座

**1.Parallel light pipe (pitch-down Angle)**

**2.Parallel light pipe (collimation level Angle)**

**3.Parallel light pipe (elevation)**

**4.Columns, the base connection screw**

**5.Adjust and fastening ring**

# **SMART MAX GEOSYSTEMS CO., LTD**

www.smartmaxgeosystems.com info@smartmaxgeosystems.com

ADD: FLAT 601, 6/F, VASTKIN HOUSE, 84 JERVOIS STREET, SHENG WAN, HONG KONG, CHINA.

**6.Fixed adjusting ring**

**7.POST**

**8.Adjust the lock screw parallel light pipe**

**9.The base leveling bolt**

**10.The base block**

**11.Leveling circular bubble**

**12.Instrument workbench**

**13.The lifting thread screw**

**14.Lift the handle**

**15.Drop brake bolt**

**16.The base**

CST3M 型测绘仪器检校台水泥平台参考尺寸图

# SMART MAX GEOSYSTEMS CO., LTD

www.smartmaxgeosystems.com info@smartmaxgeosystems.com

ADD: FLAT 601, 6/F, VASTKIN HOUSE, 84 JERVOIS STREET, SHENG WAN, HONG KONG, CHINA.

---

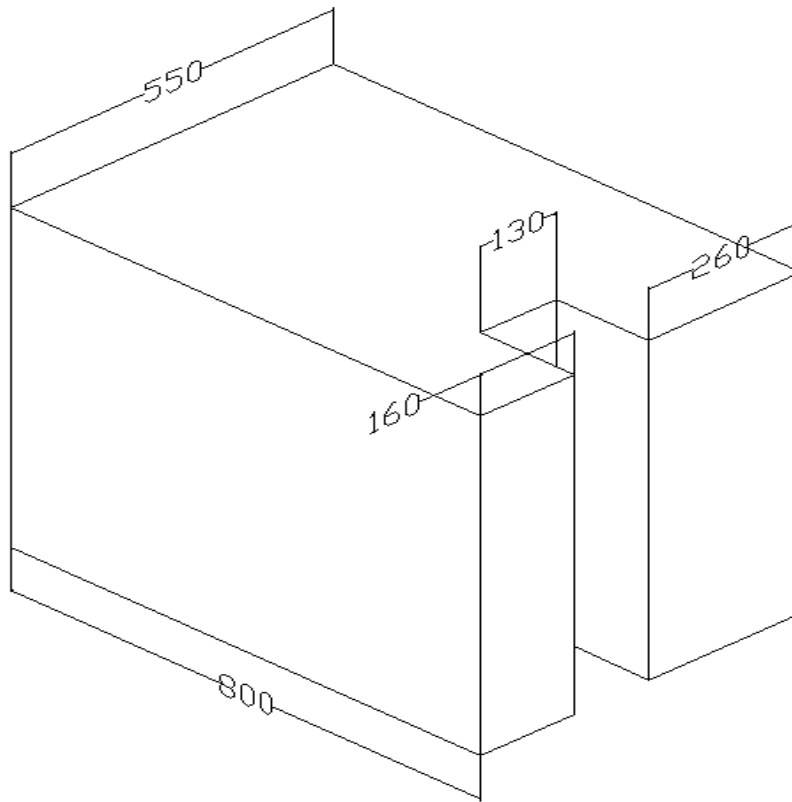

## 三、CST3M 型测绘仪器检校台安装的基本要求

### The basic requirement of surveying and mapping instruments calibration machine installation

#### 一、安装场地的基本要求：

- 1、检校台的安装摆放位置，与工作台的工作位置，应保留足够的空间。
- 2、安放检校台的水泥平台高度应根据工作需要确定。
- 3、检校台安放位置，应做好防震工作，如在落地底座下方垫一定厚度和硬度的橡胶防震，减少仪器的震动。

#### The basic requirements of installation site

1. Should keep enough space between Calibration table installation position and the working position.
2. Position calibration station cement platform height should be done according to the need to identify



# SMART MAX GEOSYSTEMS CO., LTD

www.smartmaxgeosystems.com info@smartmaxgeosystems.com

ADD: FLAT 601, 6/F, VASTKIN HOUSE, 84 JERVOIS STREET, SHENG WAN, HONG KONG, CHINA.

3. Calibration table placement, should be good sense, such as in the floor under the seat cushion thickness and hardness of rubber shockproof to reduce instrument vibration.

二、开箱检验产品及附件是否齐全。

You need to check whether the full range of products and accessories or not when open package.

三、安装方法：Method of installation

- 1、首先仔细阅读使用说明书。
  - 2、将落地底座安放在预先浇好的水泥平台上。
  - 3、将上机座、安放在底座上，用配备的 M8 螺栓连接好。
  - 4、把升降台安装到底座上。
  - 5、接通电源。
  - 6、全部安装完成后，调整底座的三个螺栓，直到把金属水泡中的水泡调到园心位置。
- 此时，底座水平调整完成。

1. Firstly, read the instruction manual installation method carefully.
2. Put the floor pedestal on the pre cast concrete platform
3. Place the machine seat in the bace seat,and equipped with M8 bolt connection.
4. Install lifting platform to the base.
5. Power on.
6. All after the completion of the installation, adjustment of base three bolt, until the metal blisters to the circle center position.

At this point, the base level adjustment is complete.

四、检校台的保养 Calibration table maintenance

# SMART MAX GEOSYSTEMS CO., LTD

www.smartmaxgeosystems.com info@smartmaxgeosystems.com

ADD: FLAT 601, 6/F, VASTKIN HOUSE, 84 JERVOIS STREET, SHENG WAN, HONG KONG, CHINA.

---

为了保证检校台的良好使用性能和寿命，应放置于干燥、通风、无振动、无酸碱性气体的室内，有条件的可放于专业的恒温定室内为最佳。

1、仪器用毕要先盖上物镜罩，并擦去表面的灰尘，在杂乱环境中使用时仪器要用专人守护。

2、仪器摆放的操作空间不能产生振动，以免影响测量检定的精度。

3、仪器任何部分产生故障，不勉强使用，应立即检查、修理，不使用时关掉电源。

4、平行光管镜片的清洁如沾染灰沙必须用专业毛刷或柔软的擦镜纸擦掉。清洁物镜表面时，请先用干净的毛刷扫去灰尘，再用干净的无线棉布沾酒精由透镜中心向外一圈圈的螺旋轻轻擦拭。去除仪器上表面的灰尘时切不可用任何稀释剂或汽油，而应用干净的布块沾中性洗涤剂擦洗。

5、在潮湿环境中应随用干净软布擦干仪器表面的水份及灰尘。

检校台如有意外情况，如强烈震动、搬移、碰撞、温度剧变，水泡偏移，分划板的偏离等须随时校正。

升降螺纹丝杆一定要定期上润滑脂，将升降手柄转动丝杆上下运动，可使润滑脂抹均匀。

各电镀部件避免接触到汗渍、油渍及水雾，随时注意擦拭以保持较好的美观度。

In order to ensure the calibration table of good service performance and life, it should be placed in dry, ventilated, no vibration, no acidity gas chamber, the best conditions is on the professional thermostat set indoors.

1. Cover an objrctive lens hood after using the instrument, and wipe off the dust on the surface . Need special care if using instrument in a cluttered environment.
2. Display apparatus operation space can't vibrate, so as not to affect the measurement accuracy.
3. Not to use if any section generates fault of the apparatus, you should check and repair it immediately. Turn off the power if not in use,.
4. The collimator lens cleaning such as contaminated dust must use

# SMART MAX GEOSYSTEMS CO., LTD

www.smartmaxgeosystems.com info@smartmaxgeosystems.com

ADD: FLAT 601, 6/F, VASTKIN HOUSE, 84 JERVOIS STREET, SHENG WAN, HONG KONG, CHINA.

professional brush or soft lens paper wipe. Clean the lens surface, please clean with a brush sweep dust, use a clean cotton cloth dipped in alcohol by wireless lens center outward circling spiral gently wipe. Apparatus for the removal of the upper surface of the dust must not use any diluent or gasoline, should use a clean cloth block with neutral detergent scrub.

5. In a humid environment should use a clean soft cloth to clean the equipment surface moisture and dust. Calibration table in case of accidental, such as strong vibration, moving, collision, temperature change, water migration, reticle deviation, shall timely correction.

Lifting screw rod must regularly with grease, the lifting handle rotates the screw rod to move up and down, can make the grease with uniform.

The plating parts to avoid exposure to sweat, grease and water mist. Always pay attention to wipe to maintain the good appearance.

## 四、检校台平等光管的偏差校正

Equal light pipe deviation correction of the calibration table.

调整前 Before adjustment

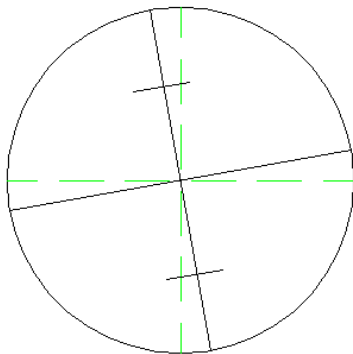

调整后 After adjustment

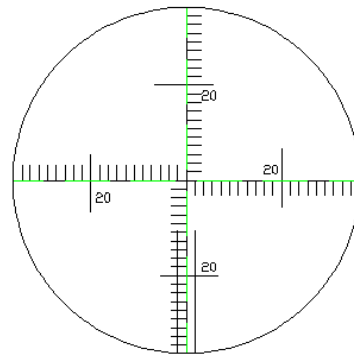

A 虚线表示平行光管位置正确

The dotted line represents the parallel light pipe is positioned correctly

B 实线表示平行光管位置不正确

The solid line shows the parallel light pipe position is not correct

# SMART MAX GEOSYSTEMS CO., LTD

www.smartmaxgeosystems.com info@smartmaxgeosystems.com

ADD: FLAT 601, 6/F, VASTKIN HOUSE, 84 JERVOIS STREET, SHENG WAN, HONG KONG, CHINA.

## 校正方法 Correction method

- 1、放松平行光管前后紧固圈座正螺丝 A、B，轻微旋转平行光管，通过仪器观察校正十字分划板的歪斜。
- 2、当需要对十字分划板，做精细的偏、正校正，可取下光管后部的照明外罩，旋转装有十字分划板的横纹轴座，通过仪器观察至正确位置后，再将照明保护罩装回正确位置。（注意在做此项操作时，建议由两位技术人员，并且不可触动和向外松动十字分划板）。

1. Relaxed parallel light pipe front and rear fastening ring seat screw A & B, rotate the parallel light pipe slightly, through the instrument observation, correction of the skew of the cross divisional board.
2. When the needs of the cross divisional board, do fine partial correction, removable light pipe rear lighting cover, rotating with the cross divisional board horizontal shaft seat, through the instrument observation to the correct position, then the lighting protection cover fitted to the correct position.( PS:, Recommended by two technical personnel in this operation, and can not touch and outward loosening cross divisional board.)

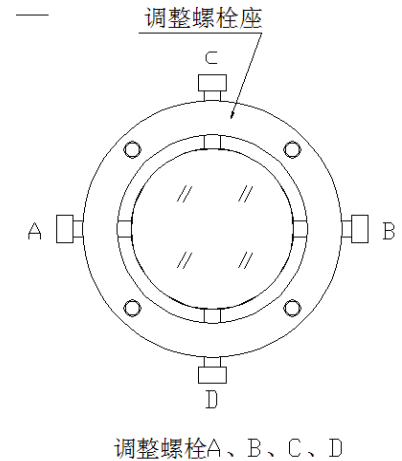

## 五、平行光管横竖纹的校正（校正水平光管的横竖丝）

Parallel light pipe horizontal and vertical lines correction(Correction of horizontal tube with vertical and horizontal wires)

调整前 Before adjustment

调整後 After adjustment

# SMART MAX GEOSYSTEMS CO., LTD

www.smartmaxgeosystems.com info@smartmaxgeosystems.com

ADD: FLAT 601, 6/F, VASTKIN HOUSE, 84 JERVOIS STREET, SHENG WAN, HONG KONG, CHINA.

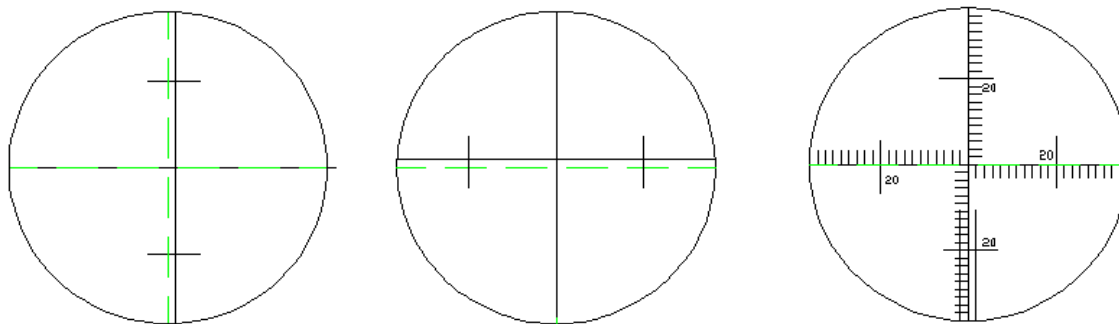

A 虚线表示平行光管位置正确

The dotted line represents the parallel light pipe is positioned correctly

B 实线表示平行光管位置不正确

The solid line shows the parallel light pipe position is not correct

## 校正方法 Correction method

放松平行光管前后紧固圈座正螺丝 A、B，或 C、D 通过仪器观察校正十字分划板的实线与虚线是否重合，重合为正确。（平行光管的水平光轴与水准仪的视准轴线互成同一水平线）

Relaxed parallel light pipe front and rear fastening ring seat screw A,B or C,D. Through the instrument observation, correct if the cross divisional board solid and dotted lines are coincident, coincidence as correct.( Parallel light pipe horizontal light axis and the leveling instrument collimation axis are in a same horizontal line)

## 六、平行光管无穷远的校正 Parallel light pipe of the infinity of correction

平行光管在出厂时已经校正好了，一般情况下是不会变动的，但通过长途的运输的震动可能会有轻微变化。如果出现变化，或安装时出现误差就需重新校正。

本校正台在第一次的检验校正时需对此项目进行检验。

使用高精度的水准仪或经纬仪，以确定调整至无穷远的清晰目标。不再转动水准仪的调焦手轮，然后检验本平行光管。

# SMART MAX GEOSYSTEMS CO., LTD

www.smartmaxgeosystems.com info@smartmaxgeosystems.com

ADD: FLAT 601, 6/F, VASTKIN HOUSE, 84 JERVOIS STREET, SHENG WAN, HONG KONG, CHINA.

检验时如果本支平行光管无穷远十字丝不清晰,可先拿下尾部的照明保护罩,检查分划板基座,向内轻推安装有分划板的横纹轴座,看是否出现向外松出的情况.

In general, the parallel light pipe at the factory have good correction,

It rarely will change, but through the long-distance transport vibrations may be a slight change. If there are changes or installation error, calibration is needed.

The correction in the first test correction is required for this project inspection

Using high precision level and theodolite, to determine the adjustment to infinity clear goals. No rotation level focusing hand wheel, and then test the parallel light pipe.

During testing, if the supporting parallel light pipe infinity cross wire is not clear, you can take rear-end lighting protection cover, check the reticle base, inward jog mounted reticle transverse shaft seat, to see if there 's outward pine.

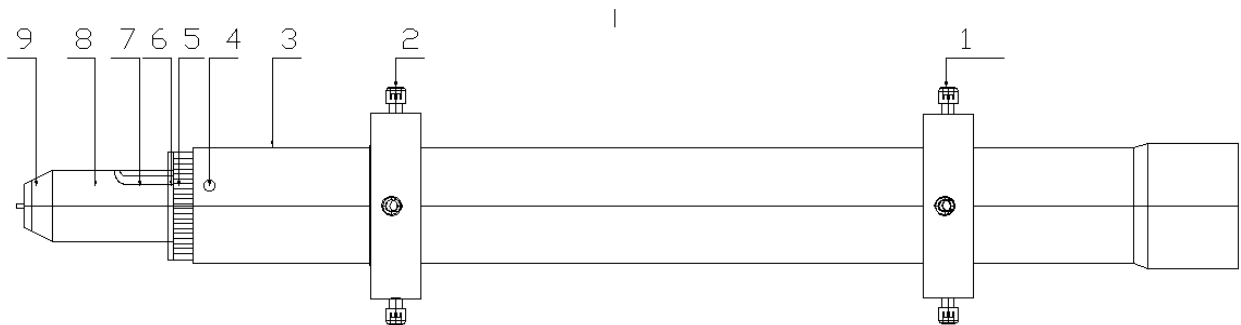

1、平行光管校正螺丝 Parallel light pipe adjusting screw

2、紧固调整圈座 Fastening adjusting ring seat

3、分划板调整螺丝 Reticle adjusting screw

4、制动锁紧螺丝 Brake locking screw

5、直纹压花紧固圈 Straight embossed fastening ring

6、分划板连接筒 Partition plate connecting tube

# SMART MAX GEOSYSTEMS CO., LTD

www.smartmaxgeosystems.com info@smartmaxgeosystems.com

ADD: FLAT 601, 6/F, VASTKIN HOUSE, 84 JERVOIS STREET, SHENG WAN, HONG KONG, CHINA.

7、照明保护罩卡口螺丝 Lighting protection hood bayonet screws

8、照明保护外罩 Lighting protection cover

9、电源线锁紧螺母 Power line lock nut

平行光管无穷远的校正方法: Parallel light pipe infinite correction method

1、放松制动锁紧螺丝 4

2、旋转放松直纹压花紧固圈 5

3、慢慢往前或往后轻轻转动，调整无穷远分划板连接筒 6

4、通过仪器观察达到最清晰效果时即可。

5、拧紧直纹压花紧固圈 5，固定制动螺丝 4，无穷远调校完成。

此时操作后，分划板出现歪斜，可按平行光管的歪斜校正方法调整好即可。

注意：以上操作时不能松动上下左右四个分划板调整螺丝 3

1. Release the brake locking screw 4

2. Rotational relaxation of straight embossed fastening ring 5

3. Slowly rotates forward or back, adjust infinite division plate connecting tube 6

4. Through the instrument observation, to achieve the most clear effect.

5. Tighten the straight embossed fastening ring 5, fixing screw 4, finish the infinite adjustment.

After the operation, if the reticle deflection, according to parallel light pipe adjusted skew correction method to correct.

PS: The above operation can not be loosened up and down around the four reticle adjusting screw 3

七、垂直天顶平行光管（垂直天顶器）调整方法：

Vertical zenith collimator adjustment method (Vertical ceiling device)

# SMART MAX GEOSYSTEMS CO., LTD

www.smartmaxgeosystems.com info@smartmaxgeosystems.com

ADD: FLAT 601, 6/F, VASTKIN HOUSE, 84 JERVOIS STREET, SHENG WAN, HONG KONG, CHINA.

---

1、使用精度为 2” 的经纬仪（通过检定，标准无误差的仪器）连接弯管目镜，安装并测试好弯管目镜，经纬仪在圆盘工作台精确定水平，通过观察使经纬仪十字丝分划板与垂直平行光管内十字丝分划板完全重合，经纬仪做盘左、盘右的操作，观察二者十字丝是否有变化，通过几次反复的观察和调整，经纬仪分划板十字丝都与平行光管十字丝分划板完全重合即可。

Use the precision for 2 " theodolite(Through the test,standar no error's apparatus)to connect elbow eyepiece, installation and test tube eyepiece, theodolite in disk worktable precision determination of equilibrium. Through observation, the theodolite cross wire reticle and vertical parallel light pipe cross wire reticle coincide completely. Do wheel left, disk right operation of the theodolite, observation if the two cross wire change. Through several times repeated observation and adjustment, theodolite cross wire reticle and parallel light pipe cross wire reticle can be completely coincide.

2、平行光管十字丝分划 出现不歪斜，调整方法请见之前所讲解的分划板十字丝歪斜的调整方法。

Parallel light pipe cross wire reticle appears not to skew, adjustment method for prior to explain the reticle crosshairs skew adjustment method.

3、如平行光管与调试经纬仪光轴前后或左右出现大的移位，可放松前后两个四方锁紧座上的锁紧手轮，通过旋转或前后推移的调整，使二者光轴相重合处于同一垂直线，调整后，再拧紧两个锁紧手轮。

If the parallel light pipe and debugging theodolite axis around or before and after a major shift, you can relax the two before and after Quartet locking seat locking hand wheel. By rotating the passage or before and after adjustment, so that the two optical axis coincide in the same vertical line. After adjustment, and then tighten the two locking hand wheel.

4、横丝与竖丝不重合的调整。当使用标准的仪器调试垂直平行光管，如出现横丝或竖丝不重合，可通过轻微旋转微动调整手轮来使二者十字丝完全重合。

Horizontal and vertical wire offset adjustment. When using the standard instrument vertical parallel optical tube, such as horizontal or vertical wires are not coincident, by slight rotation of micro adjusting hand wheel to make the two



# SMART MAX GEOSYSTEMS CO., LTD

www.smartmaxgeosystems.com info@smartmaxgeosystems.com

ADD: FLAT 601, 6/F, VASTKIN HOUSE, 84 JERVOIS STREET, SHENG WAN, HONG KONG, CHINA.

---

cross wire coincide completely.

八、望远镜准轴与竖轴不重合的调整（以苏州一光 DZJ200 型激光垂准仪为例）  
在使用过程中，如发现仪器照准部转动 180° 后，目镜的成像与望远镜十字丝中心有偏移，说明望远镜视准轴与竖轴不重合，需要调整。

Telescope alignment shaft and shaft misalignment adjustment(Take Suzhou a light type DZJ200 laser plumb instrument as an example)

During use, such as finding apparatus alidade 180 ° rotation, the imaging telescope eyepiece with crosshairs center offset, illustrate the telescope collimation axis and solid shaft misalignment, need to adjust it.

首先，将仪器安装在校正台上，使用中心螺旋固定好仪器，精确定平后，仪器对准校正台上方垂直架设的平行光管，照准调焦后（观察时尽量消除视差），通过仪器望远镜观察将分划板十字丝与观测平行光管十字丝分划板中心重合得一目标或读数，将仪器旋转 180 后再得一目标或读数。如两次目标偏移或读数不重合则需要调整。旋下检仪器调整位的黑色目镜圆罩，用校针微调分划板周围上、下、左、右四个方向上的调整螺钉，调整量为偏移量的一半，反复观测直到仪器转动任意角度，十字线的像与望远镜分划板上的十字线完全重合。之后，再旋上圆罩。

First of all, mounted the apparatus on the platform, using the center screw fixing apparatus. After precise balance, apparatus for alignment correction table vertically above the erection of the parallel light pipe, then focus on(Observation to eliminate parallax), Through the telescope observation instrument, a cross wire reticle observation and parallel light pipe cross wire reticle center coincide get a goal or reading, rotate the apparatus to 180 to get a goal or reading. If the two target offset or reading different needs to adjust.

The black eyepiece dome of adjustment of position of unscrew the calibration instrument, using the calibration pin fine-adjustment reticle around upper and lower, left and right four directions of adjustment screw, and the adjustment of the volume should be half of the offset. Repeated observations until the apparatus rotate at any angle, reticle imaging with a telescope on the reticle cross line coincide completely. At last, screw on the circular cover.

九、激光束同轴的调整 Laser beam coaxial adjustment

# SMART MAX GEOSYSTEMS CO., LTD

www.smartmaxgeosystems.com info@smartmaxgeosystems.com

ADD: FLAT 601, 6/F, VASTKIN HOUSE, 84 JERVOIS STREET, SHENG WAN, HONG KONG, CHINA.

使用过程中，如激光束聚集后，光斑不位于望远镜分划板十字丝中心，说明激光光轴与望远镜视准轴不重合，需要调整。仪器摆放在工作台上，精确定平照准垂直平行光管，精确照准后，取下激光外罩，打开垂准激光开关。亮度调整到合适观测，聚集激光束光斑，然后一边通过目镜观察，一边用改针微调激光连接座上4个水平方向上的调整螺钉，直到仪器转到任意位置，激光斑都处于望远镜划板十字丝中心。

During the use of the process, such as a laser beam after the aggregation, spot is not located in the telescope reticle crosshairs center, description of the laser and the optical axis of the telescope collimation axis misalignment, need to adjust. Apparatus is placed in the table, precise leveling and certain vertical parallel light pipe, after accurate sighting, remove the laser, and open vertical laser switch. Brightness adjustment to fit observations, aggregation of laser beam spot, then observe through an eyepiece, while using the modified needle trimming laser connecting seat 4 horizontal direction of the adjusting screw, until the apparatus to any position, the laser spot in the center of the cross wire reticle telescope.

## 十、激光束同焦的调整

用望远镜照准目标并精确调焦后，打开垂准激光开关，目标处的激光光斑直径应最小，否则说明激光束与望远光学系统不同焦，需要调整。

摆放好仪器，精确照准目标后，即十字丝或平行光管无穷远处分划板上的十字丝清晰的成像在

Use telescope sight target and precise focusing, open vertical laser switch, target laser spot diameter should be minimal, or that the laser beam and the telescopic optical system of different focal, need to adjust.

Display the apparatus, accurate sighting target,

## 十一、水准仪与水平光管 Level and horizontal smooth tubes

水平光管的水平光轴与水准仪视准轴线互成同一水平。

The horizontal axis of horizontal tube and leveling collimation axis are the same level.

# SMART MAX GEOSYSTEMS CO., LTD

www.smartmaxgeosystems.com info@smartmaxgeosystems.com

ADD: FLAT 601, 6/F, VASTKIN HOUSE, 84 JERVOIS STREET, SHENG WAN, HONG KONG, CHINA.

---

## 十二、经纬仪、全站仪与水平光管的校正

Correcting of theodolite, total station instrument and horizontal tube

平行光管十字分划板（每一小格读数为 20”）

经纬仪读数  $90^{\circ} 0' 0''$  与水平光管十字分划板完全重合

经纬仪、全站仪望远镜设置于  $90^{\circ} 0' 0''$ （或  $270^{\circ} 0' 0''$ ）位置

Parallel light pipe cross divisional board(Each section is a reading of 20 ")

Theodolite readings is  $90^{\circ} 0' 0''$  With the horizontal tube with cross graticule coincides completely

Theodolite, total station telescope, set in  $90^{\circ} 0' 0''$  ( $270^{\circ} 0' 0''$ ) position

## 十三、平行光管电源管理

Parallel optical tube power management

在使用检校台时，请注意安全用电！

In the use of the station, please use the electric safety first

将检校台的平行光管照明线插头与电源变压器插座相连接，再将电源变压器电源插头接通 220V 总电源，打开检校台电源开关（或配备的电源插座开关），此时平行光管的照明系统全部明亮。因为变压器上有明亮度调节旋钮，可根据个人的使用情况来调整明亮度。为保证照明系统经久耐用，工作完毕后，请关闭开关所有电源均已切断。

The calibration of parallel light pipe line plug socket is connected with power transformer, then connect the power transformer power plug with 220V total power. Open the power supply switch(Or with the power outlet switch), the parallel light pipe illumination system are all bright. According to personal usage to adjust brightness, because the transformer has brightness adjusting knob. In order to ensure the lighting system durability, after the work is finished, please turn off all power supply switch.

注意：在连接平行光管照明电源线时，不可扭曲及拉扯电源线。

# SMART MAX GEOSYSTEMS CO., LTD

www.smartmaxgeosystems.com info@smartmaxgeosystems.com

ADD: FLAT 601, 6/F, VASTKIN HOUSE, 84 JERVOIS STREET, SHENG WAN, HONG KONG, CHINA.

PS: Connected in parallel light pipe illumination power line, can not be distorted or pulling power line.

照明系统不亮的排查:

- 1、检查平行光管照明插头与电源变压器接插座是否准确连接。
- 2、电源变压器电源线插头与总电源是否准确连接。
- 3、检查电源变压器电源线插头内电源线是否松脱。
- 4、检查电源变压器内电源线是否出现故障。
- 5、打开平行光管照明保护外罩，检查照明器后部接线是否松脱。

Lighting system is not the brightest investigation:

1. Check if the parallel light pipe plug and socket connection of power transformer is accurated.
2. Check if the power transformer power line plug and a general power supply is accurate connection
3. Check if the power transformer power line plug power line is loose.
4. Check if the power transformer in the power line is failure.
5. Open parallel light pipe protection cover, check if the lighting device rear wiring is loose.